

CANDIDATE  
NAME

|  |
|--|
|  |
|--|

CENTRE  
NUMBER

|  |  |  |  |  |
|--|--|--|--|--|
|  |  |  |  |  |
|--|--|--|--|--|

CANDIDATE  
NUMBER

|  |  |  |  |
|--|--|--|--|
|  |  |  |  |
|--|--|--|--|

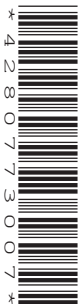

**CO-ORDINATED SCIENCES**

**0654/32**

Paper 3 (Extended)

**October/November 2016**

**2 hours**

Candidates answer on the Question Paper.

No Additional Materials are required.

**READ THESE INSTRUCTIONS FIRST**

Write your Centre number, candidate number and name on all the work you hand in.

Write in dark blue or black pen.

You may use an HB pencil for any diagrams or graphs.

Do not use staples, paper clips, glue or correction fluid.

**DO NOT WRITE IN ANY BARCODES.**

Answer **all** questions.

Electronic calculators may be used.

You may lose marks if you do not show your working or if you do not use appropriate units.

A copy of the Periodic Table is printed on page 36.

At the end of the examination, fasten all your work securely together.

The number of marks is given in brackets [ ] at the end of each question or part question.

This document consists of **36** printed pages.

1 Fig. 1.1 shows a plant root hair in the soil. The root hair cell absorbs water from the soil by osmosis.

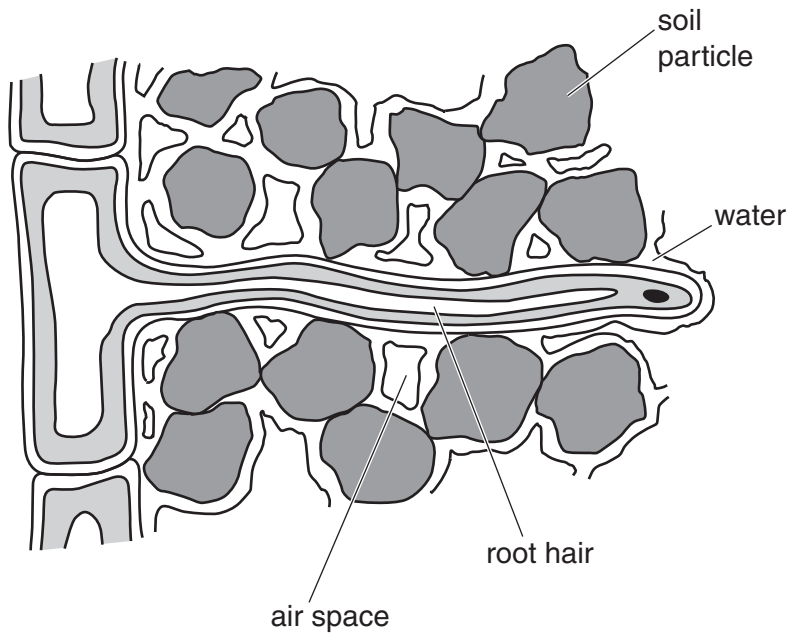

Fig. 1.1

(a) Define the term *osmosis*.

.....  
.....  
.....  
.....[3]

(b) Describe how the structure of the root hair cell is adapted to absorb water efficiently.

.....  
.....  
.....[2]

(c) The soil surrounding a root hair cell becomes flooded with seawater, which has a very high concentration of salts.

Suggest and explain what effect this has on

(i) the contents of the root hair cell,

.....  
.....  
.....[2]

(ii) the leaves of the plant.

.....  
.....  
.....[2]

(d) Water is a raw material for photosynthesis.

(i) Name **one other** substance that is a raw material for photosynthesis.

.....[1]

(ii) Name a **substance** that is needed for photosynthesis that is **not** used up by the process.

.....[1]

2 Table 2.1 shows some information about three elements in Period 3 of the Periodic Table.

**Table 2.1**

| element | electron arrangement | relative reactivity |
|---------|----------------------|---------------------|
| Na      | 2,8,1                | most<br>↑<br>least  |
| Mg      | 2,8,2                |                     |
| Ar      | 2,8,8                |                     |

(a) (i) Explain why argon atoms do **not** form chemical bonds.

.....

.....

.....[2]

(ii) A student uses the information in Table 2.1 to make the following conclusion.

*From left to right across Period 3 the elements become less and less reactive.*

Explain why this conclusion is **incorrect**.

.....

.....[1]

(b) Fig. 2.1 shows apparatus used to investigate how the change in acid concentration affects the speed of reaction between dilute sulfuric acid and excess magnesium.

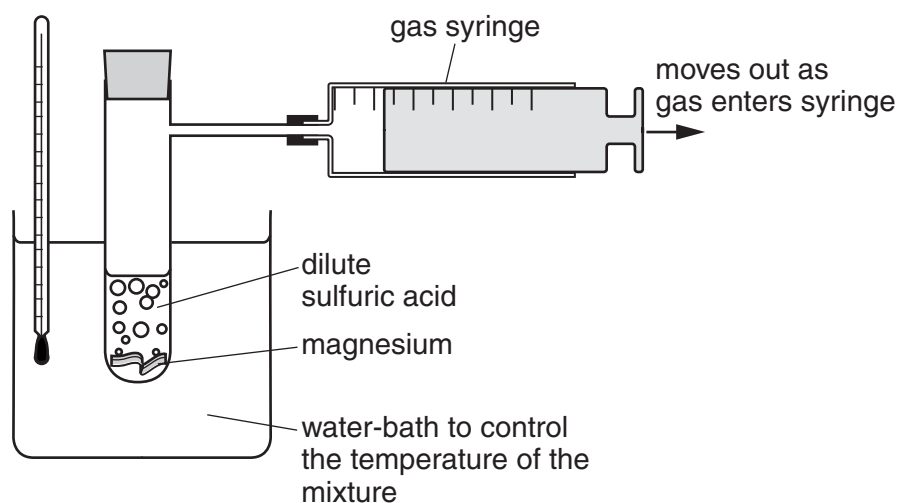

**Fig. 2.1**

The only variable that changes in this investigation is the concentration of the acid.

Table 2.2 shows the acid concentration and the speed of reaction.

**Table 2.2**

| acid concentration<br>/mol per dm <sup>3</sup> | speed of reaction<br>/cm <sup>3</sup> of gas produced per second |
|--|--|
| 0.2  | 1.5  |
| 0.4  | 3.0  |
| 0.6  | 4.5  |
| 0.8  | 6.0  |

- (i) Use the results in Table 2.2 to predict the acid concentration that is required to produce 9.0 cm<sup>3</sup> of gas per second.

Explain your answer.

acid concentration ..... mol per dm<sup>3</sup>

explanation .....  
 .....  
 ..... [2]

- (ii) Use the results in Table 2.2 to explain, in terms of particles, the effect of increasing acid concentration on the speed of reaction.

.....  
 .....  
 ..... [2]

3 Fig. 3.1 shows a man bungee-jumping from a bridge.

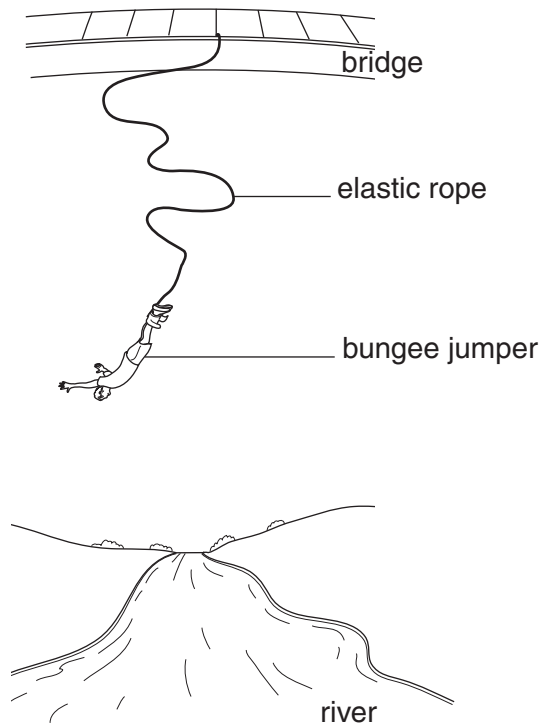

**Fig. 3.1**

The man is attached to one end of an elastic rope. The other end of the rope is attached to the bridge. The man jumps from the bridge.

(a) Name the force that makes the man fall towards the river.

.....[1]

(b) The rope is elastic and behaves like a spring. A perfect spring will obey Hooke's Law.

State Hooke's Law.

.....  
.....[1]

(c) Fig. 3.2 shows the speed/time graph for the man during part of the jump.

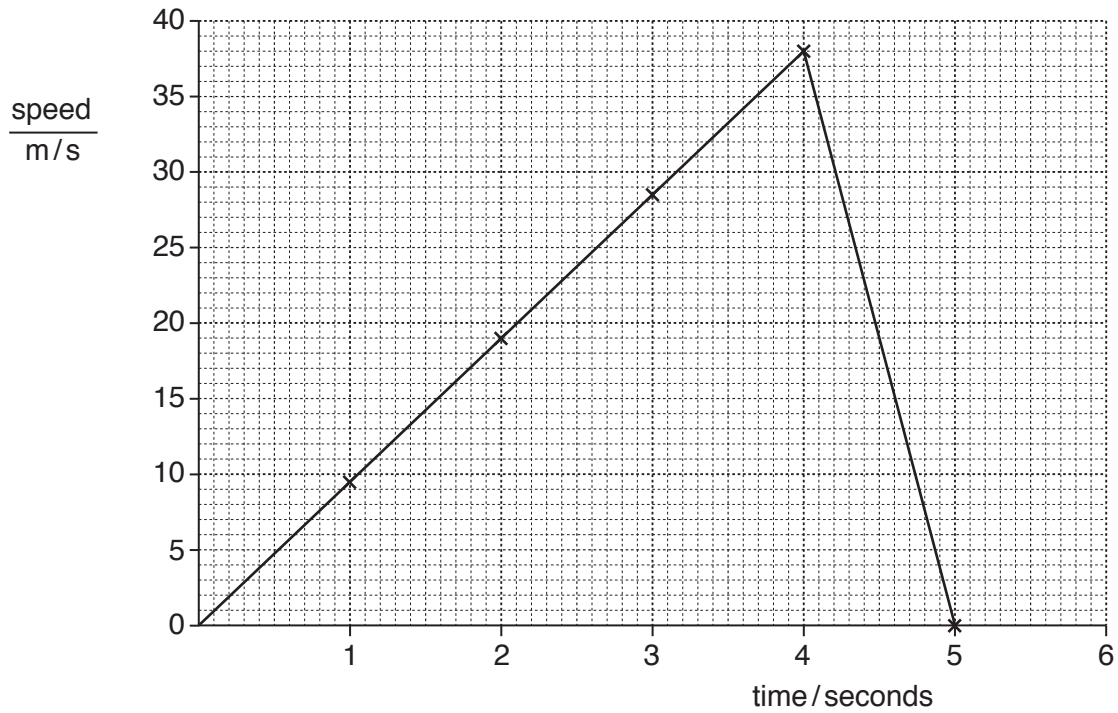

**Fig. 3.2**

(i) Write down the maximum speed of the man.

..... m/s [1]

(ii) Calculate the acceleration of the man for the first 4 seconds.

Show your working.

acceleration = ..... m/s<sup>2</sup> [2]

(iii) Calculate the distance travelled by the man during the first 5 seconds of his jump.

Show your working.

distance = ..... m [2]

(iv) The mass of the man is 90 kg.

Calculate the maximum kinetic energy of the man during his fall.

State the formula you use and show your working.

formula

working

maximum kinetic energy = ..... J [2]

(d) Suggest what happens to the motion of the man after 5 seconds.

.....  
.....[1]



4 Fig. 4.1 shows part of the human gas exchange system.

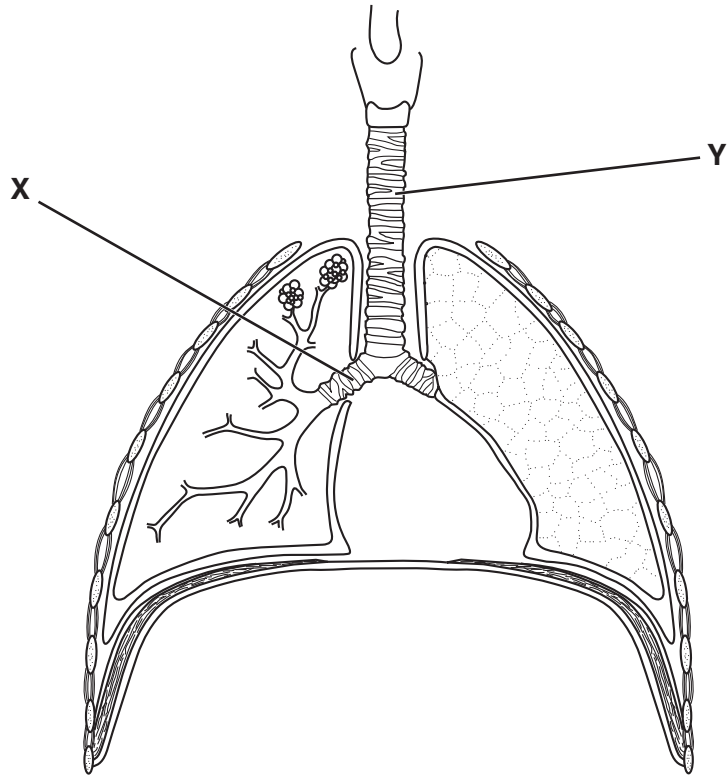

Fig. 4.1

(a) Name the structures labelled X and Y.

X .....

Y .....

[2]

(b) State **three** ways in which the air breathed out of the lungs is different from the air breathed in.

1 .....

2 .....

3 .....

[3]

(c) The graph in Fig. 4.2 shows how the carbon monoxide concentration in a person’s blood changes when a cigarette is smoked.



Fig. 4.2

(i) State how long it takes, after the person finishes smoking the cigarette, for their blood carbon monoxide concentration to return to its original level.

..... minutes [1]

(ii) On Fig. 4.2, draw a curve to show how you would expect this person’s blood carbon monoxide concentration to change if they smoked another identical cigarette, smoked in a similar way to the first, during time 50–54 minutes. [2]

(iii) If an athlete smokes, carbon monoxide enters the bloodstream and reduces the athlete’s performance.

Explain why carbon monoxide in the blood has this effect.

.....  
 .....  
 .....  
 ..... [2]

5 Many useful elements are extracted from compounds found in the Earth's crust.

(a) Table 5.1 shows the chemical formulae of raw materials used in the extraction of three elements.

Complete the table to show the **names** of the useful elements extracted.

**Table 5.1**

| formulae of raw materials used in the extraction process | extraction process used | <b>name</b> of useful element |
|--|-------------------------|-------------------------------|
| $Al_2O_3$<br>$Na_3AlF_6$ (cryolite)                      | electrolysis            |                               |
| C<br>$Fe_2O_3$ (hematite)<br>$O_2$ (from air)            | chemical reduction      |                               |
| $NaCl$<br>$H_2O$   | electrolysis            |                               |

[3]

(b) Limestone contains mainly calcium carbonate.

Fig. 5.1 shows a limekiln in which limestone changes into lime, calcium oxide.

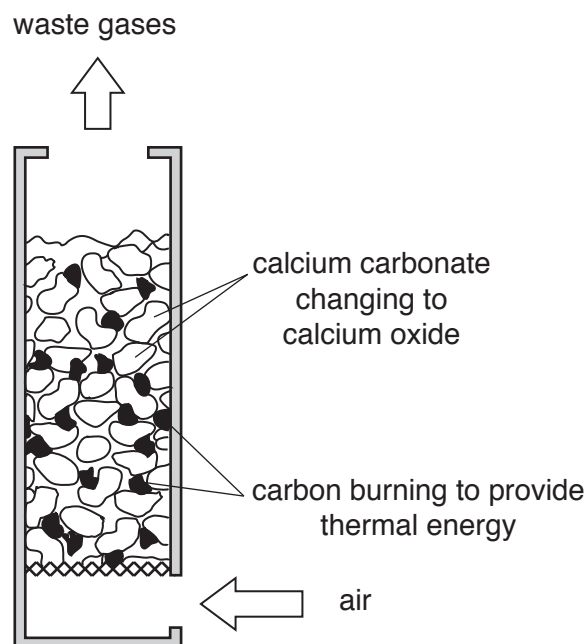

**Fig. 5.1**

Calcium carbonate changes to calcium oxide only when the carbon in the limekiln burns to provide thermal energy.

The word equation for the reaction in this process is:



Choose **two** words from the list which describe this chemical reaction.

**addition**

**cracking**

**decomposition**

**endothermic**

**exothermic**

**neutralisation**

**oxidation**

**reduction**

1 .....

2 .....

[2]

- (c) (i) Calcium oxide is an ionic compound. Calcium is in Group II of the Periodic Table and oxygen is in Group VI.

Explain, in terms of atomic structure, why a calcium ion has a charge of 2+, and why an oxide ion has a charge of 2–.

You may draw a diagram if it helps your answer.

.....  
.....  
.....  
.....  
.....[3]

- (ii) Use your answer to part (c)(i) to explain why the formula of calcium oxide is CaO.

.....  
.....[1]

- (d) The balanced equation for the conversion of calcium carbonate to calcium oxide is shown below.



A sample of limestone contains 95% by mass of calcium carbonate.

Use the four steps below to determine the mass of calcium oxide that can be obtained from 1.0 kg of this limestone.

step 1

Calculate the mass of calcium carbonate in 1.0 kg of limestone.

.....g

step 2

Calculate the number of moles of calcium carbonate in 1.0 kg of limestone.

[relative formula mass of calcium carbonate = 100]

State the number of moles of calcium oxide that are produced.

moles of calcium carbonate .....

moles of calcium oxide .....

step 3

Calculate the relative formula mass of calcium oxide.

[Ca, 40; O, 16]

.....

step 4

Use your answers in step 2 and step 3 to calculate the mass of calcium oxide that can be obtained from 1.0 kg of limestone.

.....g

[4]

- 6 (a) A saucepan manufacturer is investigating the best materials to make a saucepan. The saucepan will be heated on the hot plate of an electric cooker.

The manufacturer looks at the information in Table 6.1.

**Table 6.1**

| material  | density<br>g/cm <sup>3</sup> | electrical<br>conductivity | thermal<br>conductivity | thermal<br>expansion |
|-----------|------------------------------|----------------------------|-------------------------|----------------------|
| aluminium | 2.7                          | high                       | high                    | high                 |
| copper    | 9.0                          | very high                  | very high               | high                 |
| glass     | 2.6                          | very low                   | low                     | average              |
| plastic   | 0.9                          | none                       | very low                | none                 |
| steel     | 8.0                          | average                    | average                 | high                 |
| wood      | 0.7                          | very low                   | low                     | low                  |

Use the information in Table 6.1 to decide which material would be the most suitable material to use for the parts of the saucepan listed. Give reasons for your answers.

the base of the saucepan .....

reason .....

the handle of the saucepan .....

reason .....

[2]

- (b) Some water is heated in the saucepan.

The liquid water turns into the gas steam when it boils.

Describe the differences between water at 20 °C and steam in terms of

- the distances between the molecules,
- the forces between the molecules,
- the motion of the molecules.

.....

.....

.....

.....

.....

.....

.....

.....

[3]

- (c) The specific heat capacity of water is  $4200 \text{ J/kg}^\circ\text{C}$ . Calculate the energy required to heat  $0.8 \text{ kg}$  of water from  $20^\circ\text{C}$  to  $90^\circ\text{C}$ .

State the formula you use and show your working.

formula

working

energy = .....J [3]



**Please turn over for Question 7.**

- 7 Some people are born with six toes on each foot, as shown in Fig. 7.1. This is called polydactyly. Polydactyly is caused by a dominant allele. The allele for five toes is recessive.

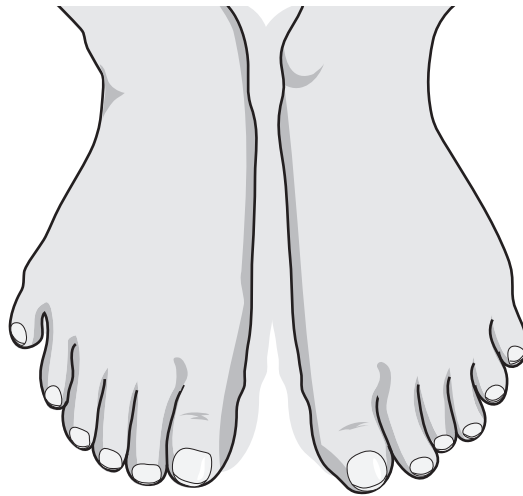

Fig. 7.1

Fig. 7.2 is a genetic diagram showing the inheritance of polydactyly in one family. **P** is the allele for polydactyly and **p** is the allele for five toes.

|                       |  |                   |             |                         |
|-----------------------|--|-------------------|-------------|-------------------------|
| <b>parents:</b>       |  |                   |             |                         |
| phenotypes            |  | polydactyly       |             | polydactyly             |
| genotypes             |  | <b>Pp</b>         |             | <b>Pp</b>               |
| gametes               |  | <b>P</b> <b>p</b> |             | <b>P</b> <b>p</b>       |
| <b>F1 generation:</b> |  |                   |             |                         |
| genotypes             |  | <b>PP</b>         | <b>Pp</b>   | <b>Pp</b> <b>pp</b>     |
| phenotypes            |  | polydactyly       | polydactyly | polydactyly   five toes |

Fig. 7.2

- (a) State the correct terms to describe
- (i) a genotype with two identical alleles, for example **PP** or **pp**,  
 .....[1]
  - (ii) a genotype with two different alleles, for example **Pp**,  
 .....[1]
  - (iii) the **type** of variation shown in polydactyly, where there are two distinct phenotypes.  
 .....[1]

(b) Use the information in Fig. 7.2 to predict the probability

(i) that a child of the F1 generation will inherit polydactyly,

.....[1]

(ii) that a child of the F1 generation has polydactyly and is **also** a carrier of the allele for five toes.

.....[1]

(c) Characteristics such as polydactyly may suddenly appear in a family even if there is no history of the condition in previous generations.

Suggest and describe how this could occur.

.....  
.....  
.....[2]

- 8 (a) Hydrogen chloride gas,  $\text{HCl}$ , is a covalent compound. It is formed when hydrogen and chlorine combine.

Fig. 8.1 shows diagrams of the arrangements of outer electrons in molecules of hydrogen and of chlorine.

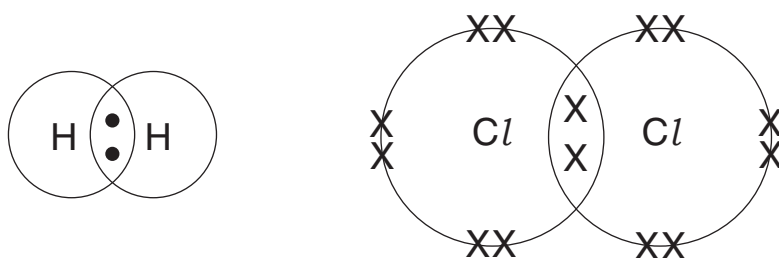

Fig. 8.1

Draw a diagram to show the arrangement of outer electrons in a molecule of hydrogen chloride gas.

[2]

(b) Hydrochloric acid is made when hydrogen chloride gas dissolves in water.

Hydrochloric acid is a solution containing hydrogen ions,  $H^+$ , and chloride ions,  $Cl^-$ .

Fig. 8.2 shows apparatus a student uses to investigate the electrolysis of dilute hydrochloric acid.

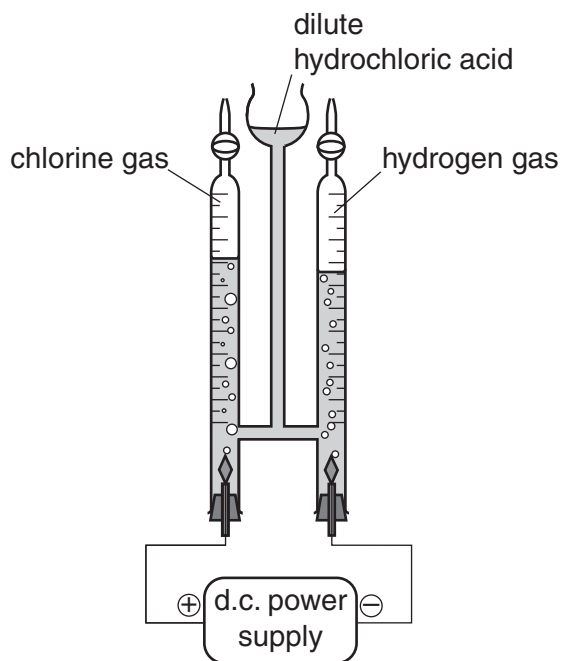

**Fig. 8.2**

Describe how chloride ions change to chlorine gas.

.....

.....

.....

..... [3]

- (c) Fluorine and iodine are in the same group of the Periodic Table as chlorine.

A student uses the apparatus shown in Fig. 8.3 to pass chlorine gas through colourless solutions of potassium fluoride and potassium iodide.

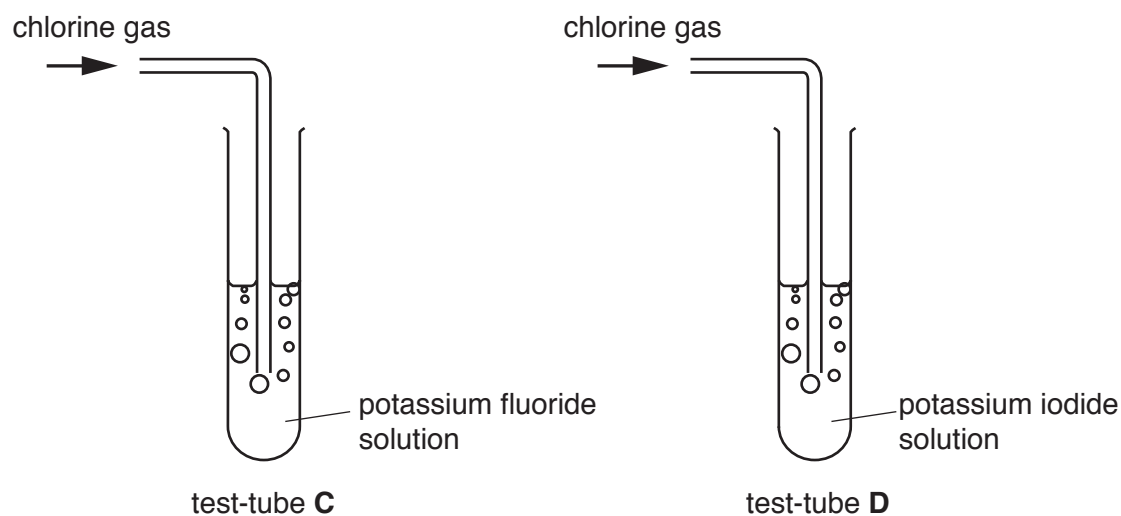

**Fig. 8.3**

- (i) Predict the change in appearance, if any, of the solutions in test-tubes **C** and **D**.

test-tube **C** .....

test-tube **D** .....

[2]

- (ii) Explain, in terms of reactivity, your answers to (c)(i).

test-tube **C** .....

.....

test-tube **D** .....

.....

[2]

9 A mountaineer is climbing a high mountain.

(a) The boiling point of water is lower at the top of the mountain than at the bottom.

Define the term *boiling point*.

.....  
 .....[1]

(b) As he climbs higher, the mountaineer is exposed to more ultraviolet radiation. Ultraviolet radiation is part of the electromagnetic spectrum.

(i) Place ultraviolet in the correct position in the incomplete electromagnetic spectrum below.

|  |        |  |               |  |            |  |
|--|--------|--|---------------|--|------------|--|
|  | X-rays |  | visible light |  | microwaves |  |
|--|--------|--|---------------|--|------------|--|

[1]

(ii) State the speed, in km/s, at which all electromagnetic waves travel.

..... km/s [1]

(iii) Ultraviolet radiation is ionising radiation.

Name **one** other type of ionising radiation.

.....[1]

- (c) The mountaineer takes a bottle containing water to the top of the mountain. At the top of the mountain, he removes the cap from the bottle, drinks the water and replaces the cap securely.

Fig. 9.1A shows the empty bottle.

When he safely reaches the bottom of the mountain, he notices that the bottle has collapsed. This is shown in Fig. 9.1B.



**Fig. 9.1A**



**Fig. 9.1B**

At the top of the mountain the volume of air in the bottle is  $330 \text{ cm}^3$ . The atmospheric pressure is  $5 \times 10^4 \text{ Pa}$ .

Atmospheric pressure at the bottom of the mountain is  $1 \times 10^5 \text{ Pa}$ .

Calculate the volume of the air inside the collapsed bottle at the bottom of the mountain.

Assume that there is no change in temperature.

State the formula you use and show your working.

formula

working

volume = .....  $\text{cm}^3$  [2]



- (d) The mountaineer lights a small fire by using a lens to focus the Sun's rays. This is shown in Fig. 9.2.

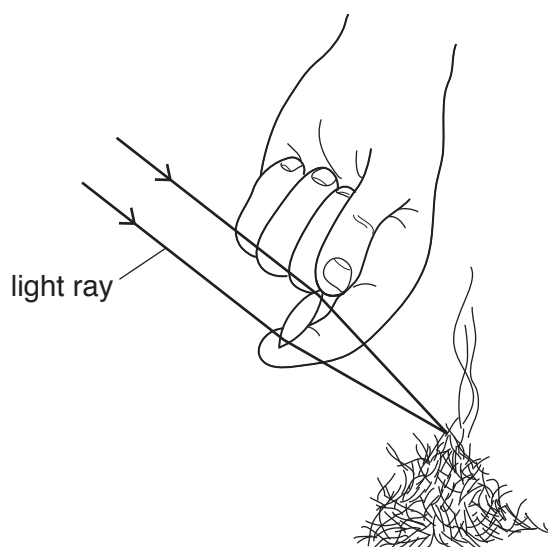

**Fig. 9.2**

- (i) Use a labelling line to show the principal focus of the lens. Label the line **P**. [1]
- (ii) Use a double headed arrow ( $\longleftrightarrow$ ) to indicate the focal length of the lens. Label it with the letter **F**. [1]

10 Rainwater was collected from four different areas over a period of one month.

Table 10.1 shows the amounts of rainwater collected in each area, and also the pH of the water.

**Table 10.1**

| area | volume of rainwater collected/cm <sup>3</sup> | pH  |
|------|---|-----|
| 1    | 25  | 5.7 |
| 2    | 19  | 3.5 |
| 3    | 37  | 7.0 |
| 4    | 15  | 6.8 |

(a) State the area listed in Table 10.1 that is most affected by acid rain. Explain how you arrived at this answer.

area .....

explanation .....

..... [1]

(b) Suggest a reason why there is acid rain in this area.

.....  
 ..... [1]

(c) Give **two** harmful effects of acid rain.

1 .....  
 2 ..... [2]

(d) Suggest **two** ways in which governments could reduce the problem of acid rain.

1 .....  
 2 ..... [2]

11 (a) Fig. 11.1 shows a fractional distillation column.

Three of the fractions obtained from the column are shown.

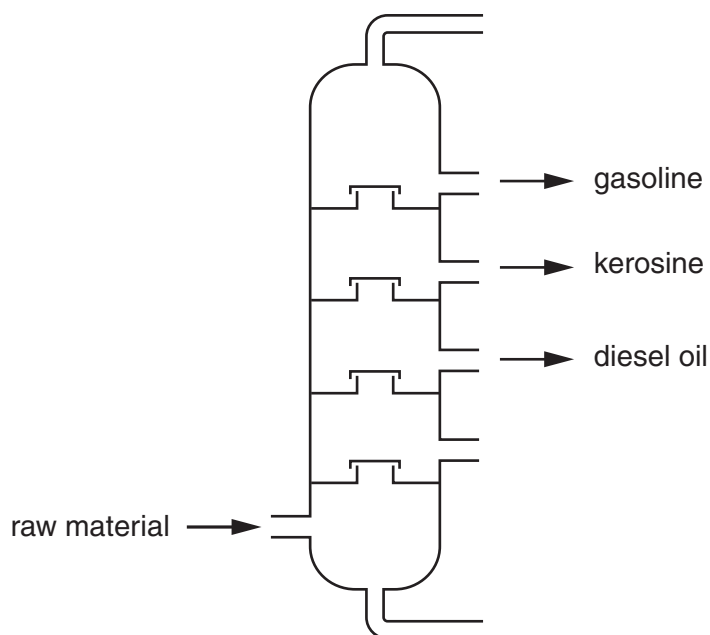

Fig. 11.1

(i) Name the raw material that is used.

..... [1]

(ii) On Fig. 11.1, use the letter **R** to label the point where refinery gases leave the column. [1]

(iii) State the fraction shown in Fig. 11.1 that has the highest boiling point range.

Explain your answer using ideas about molecules.

fraction .....

explanation .....

.....

..... [2]

(iv) Name **two** compounds that are produced when gasoline, diesel and kerosine undergo complete combustion.

1 .....

2 ..... [1]

- (b) Hydrocarbon **X** contains four carbon atoms in each of its molecules.

Hydrocarbon **X** does **not** change a solution of bromine from orange to colourless.

State and explain which of the hydrocarbons below is hydrocarbon **X**.

**butane**

**butene**

**propane**

**propene**

hydrocarbon **X** is .....

explanation .....

.....

.....

[2]

- (c) Methane,  $\text{CH}_4$ , and steam react together to produce hydrogen gas,  $\text{H}_2$ , and carbon monoxide,  $\text{CO}$ .

- (i) Construct a balanced equation for this reaction. Include state symbols.

.....[3]

- (ii) Hydrogen produced in this reaction is used in the Haber process.

Write the **word** equation for the reaction that uses hydrogen in the Haber process.

.....[1]

**Please turn over for Question 12.**

- 12 (a) An engineer is checking a thermistor used in a temperature gauge for use in a car. She connects the thermistor into the circuit shown in Fig. 12.1.

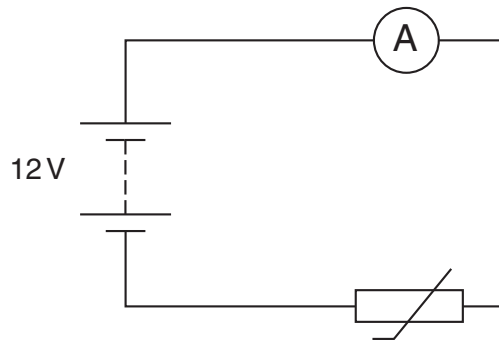

Fig. 12.1

She heats the thermistor and measures the current at different temperatures. Her results are plotted on the graph in Fig. 12.2.

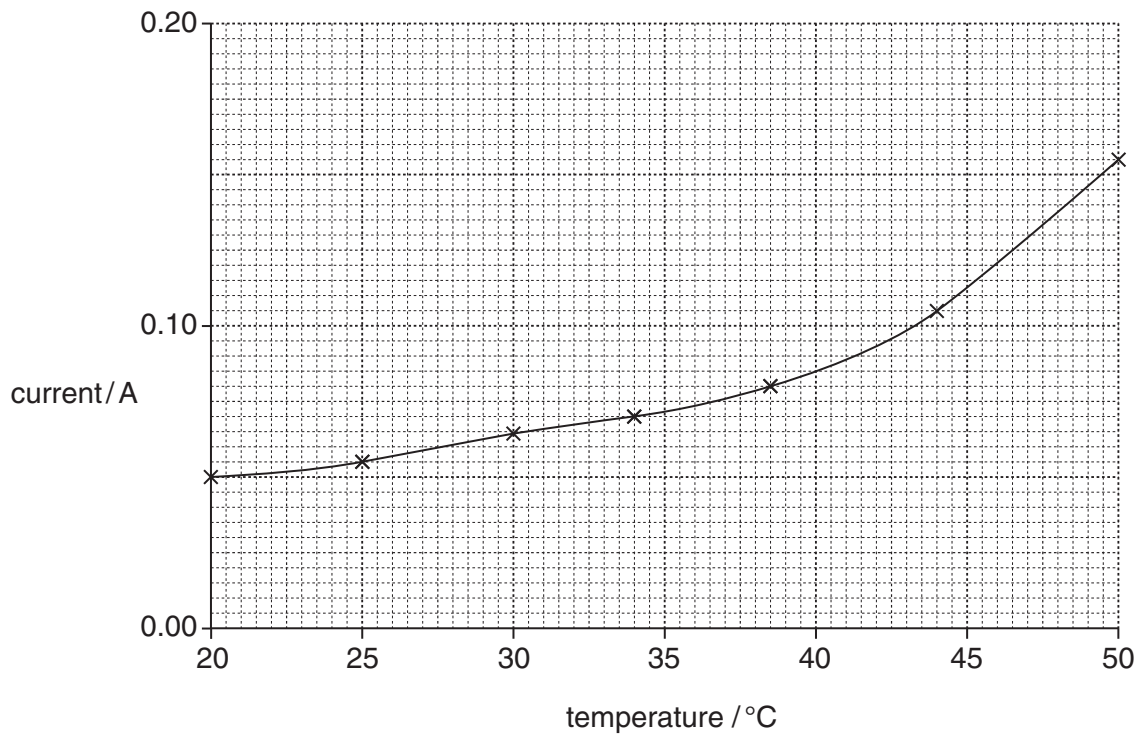

Fig. 12.2

(i) State the current passing through the thermistor at 47 °C.

.....A [1]

(ii) The supply voltage is 12 V.

Calculate the resistance of the thermistor at 47 °C.

State the formula you use, show your working and state the unit of your answer.

formula

working

resistance = ..... unit = ..... [3]

(iii) Use the graph in Fig. 12.2 to describe what happens to the current in the thermistor as the temperature increases.

.....  
.....[1]

(iv) Use the graph in Fig. 12.2 to explain the relationship between resistance and temperature for the thermistor.

.....  
.....[1]

(b) The car has a generator.

Fig. 12.3 shows a simple generator producing an alternating voltage.

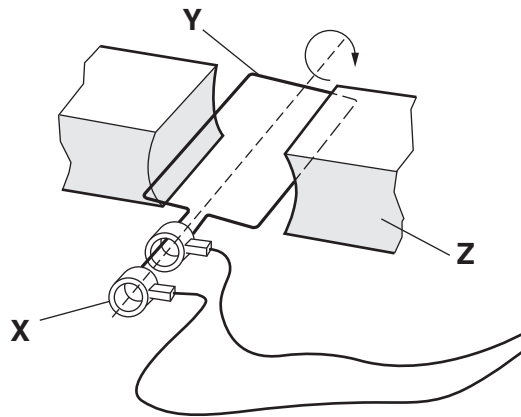

Fig. 12.3

(i) Draw **one** straight line from each letter to its correct label.

| letter | label     |
|--------|-----------|
|        | axle      |
| X      | brush     |
| Y      | coil      |
| Z      | magnet    |
|        | slip ring |

[2]



- (ii) On the grid below sketch a graph of voltage output against time for a simple a.c. generator.

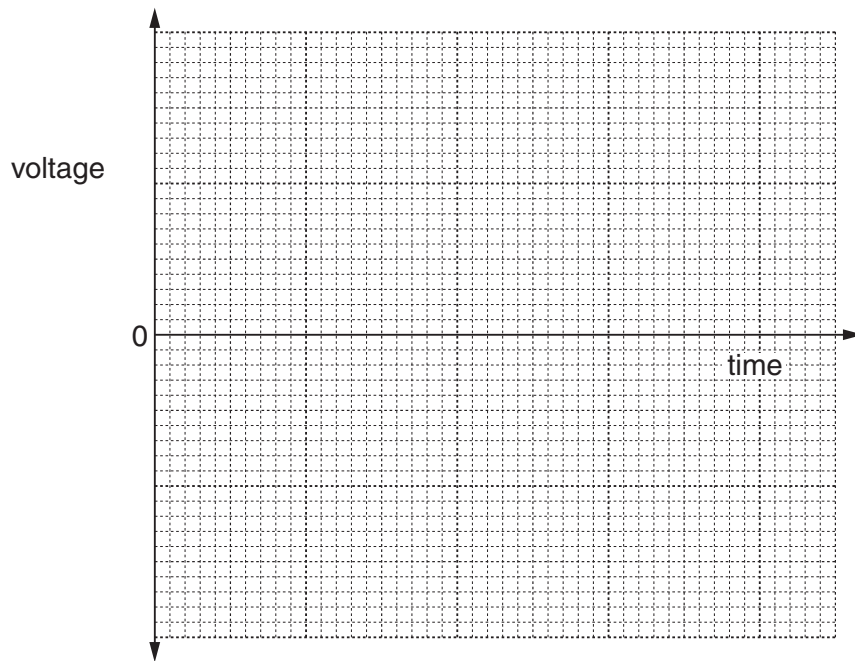

[2]

- (c) (i) The generator in the car is noisy and emits sound waves which pass through the air. The speed of sound in air is 330 m/s and the wavelength of the sound waves is 0.7 m.

Calculate the frequency of the sound waves.

State the formula you use and show your working.

formula

working

frequency = ..... Hz [2]

- (ii) The sound waves pass through the air as a series of compressions (C) and rarefactions (R).

Fig. 12.4 shows the positions of the compressions and rarefactions as the sound wave passes through the air.



Fig. 12.4

On Fig. 12.4 mark **one** wavelength with a double headed arrow ( $\longleftrightarrow$ ). [1]

- (iii) The frequency of the sound wave increases.

Describe how the diagram shown in Fig. 12.4 changes.

.....  
 .....[1]

13 Fig. 13.1 shows the structure of the human eye in horizontal section.

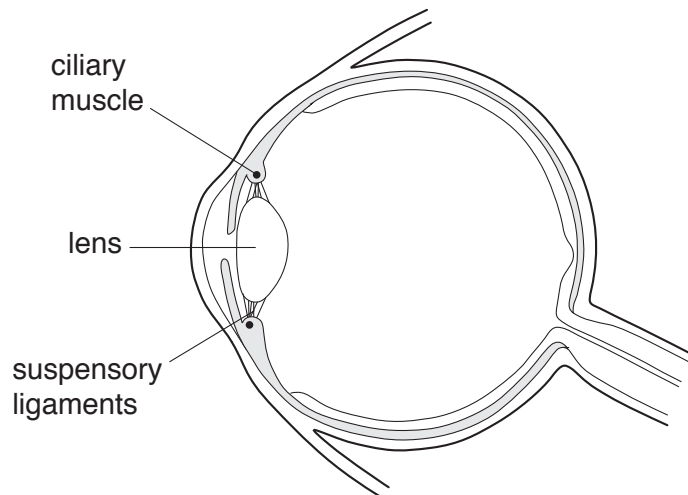

Fig. 13.1

(a) On Fig. 13.1, label

(i) the iris, [1]

(ii) the retina. [1]

(b) When the eye changes focus from a near to a distant object, state what changes occur in

(i) the lens,  
 .....[1]

(ii) the ciliary muscle,  
 .....[1]

(iii) the suspensory ligaments.  
 .....[1]

(c) Suggest what effect it would have on a person's vision if the ciliary muscle became weakened.

.....  
 .....[1]

## The Periodic Table of Elements

|                            |                             | Group                       |                                 |                             |                              |                              |                              |                              |                                |                               |                               |                             |                               |                             |                              |                           |                           |  |  |
|----------------------------|-----------------------------|-----------------------------|---------------------------------|-----------------------------|------------------------------|------------------------------|------------------------------|------------------------------|--------------------------------|-------------------------------|-------------------------------|-----------------------------|-------------------------------|-----------------------------|------------------------------|---------------------------|---------------------------|--|--|
| I                          | II                          | III                         | IV                              | V                           | VI                           | VII                          | VIII                         |                              |                                |                               |                               |                             |                               |                             |                              |                           |                           |  |  |
| 3<br>Li<br>lithium<br>7    | 4<br>Be<br>beryllium<br>9   | 5<br>B<br>boron<br>11       | 6<br>C<br>carbon<br>12          | 7<br>N<br>nitrogen<br>14    | 8<br>O<br>oxygen<br>16       | 9<br>F<br>fluorine<br>19     | 10<br>Ne<br>neon<br>20       |                              |                                |                               |                               |                             |                               |                             |                              |                           |                           |  |  |
| 11<br>Na<br>sodium<br>23   | 12<br>Mg<br>magnesium<br>24 | 13<br>Al<br>aluminium<br>27 | 14<br>Si<br>silicon<br>28       | 15<br>P<br>phosphorus<br>31 | 16<br>S<br>sulfur<br>32      | 17<br>Cl<br>chlorine<br>35.5 | 18<br>Ar<br>argon<br>40      |                              |                                |                               |                               |                             |                               |                             |                              |                           |                           |  |  |
| 19<br>K<br>potassium<br>39 | 20<br>Ca<br>calcium<br>40   | 21<br>Sc<br>scandium<br>45  | 22<br>Ti<br>titanium<br>48      | 23<br>V<br>vanadium<br>51   | 24<br>Cr<br>chromium<br>52   | 25<br>Mn<br>manganese<br>55  | 26<br>Fe<br>iron<br>56       | 27<br>Co<br>cobalt<br>59     | 28<br>Ni<br>nickel<br>59       | 29<br>Cu<br>copper<br>64      | 30<br>Zn<br>zinc<br>65        | 31<br>Ga<br>gallium<br>70   | 32<br>Ge<br>germanium<br>73   | 33<br>As<br>arsenic<br>75   | 34<br>Se<br>selenium<br>79   | 35<br>Br<br>bromine<br>80 | 36<br>Kr<br>krypton<br>84 |  |  |
| 37<br>Rb<br>rubidium<br>85 | 38<br>Sr<br>strontium<br>88 | 39<br>Y<br>yttrium<br>89    | 40<br>Zr<br>zirconium<br>91     | 41<br>Nb<br>niobium<br>93   | 42<br>Mo<br>molybdenum<br>96 | 43<br>Tc<br>technetium<br>—  | 44<br>Ru<br>ruthenium<br>101 | 45<br>Rh<br>rhodium<br>103   | 46<br>Pd<br>palladium<br>106   | 47<br>Ag<br>silver<br>108     | 48<br>Cd<br>cadmium<br>112    | 49<br>In<br>indium<br>115   | 50<br>Sn<br>tin<br>119        | 51<br>Sb<br>antimony<br>122 | 52<br>Te<br>tellurium<br>128 | 53<br>I<br>iodine<br>127  | 54<br>Xe<br>xenon<br>131  |  |  |
| 55<br>Cs<br>caesium<br>133 | 56<br>Ba<br>barium<br>137   | 57–71<br>lanthanoids        | 72<br>Hf<br>hafnium<br>178      | 73<br>Ta<br>tantalum<br>181 | 74<br>W<br>tungsten<br>184   | 75<br>Re<br>rhenium<br>186   | 76<br>Os<br>osmium<br>190    | 77<br>Ir<br>iridium<br>192   | 78<br>Pt<br>platinum<br>195    | 79<br>Au<br>gold<br>197       | 80<br>Hg<br>mercury<br>201    | 81<br>Tl<br>thallium<br>204 | 82<br>Pb<br>lead<br>207       | 83<br>Bi<br>bismuth<br>209  | 84<br>Po<br>polonium<br>—    | 85<br>At<br>astatine<br>— | 86<br>Rn<br>radon<br>—    |  |  |
| 87<br>Fr<br>francium<br>—  | 88<br>Ra<br>radium<br>—     | 89–103<br>actinoids         | 104<br>Rf<br>rutherfordium<br>— | 105<br>Db<br>dubnium<br>—   | 106<br>Sg<br>seaborgium<br>— | 107<br>Bh<br>bohrium<br>—    | 108<br>Hs<br>hassium<br>—    | 109<br>Mt<br>meitnerium<br>— | 110<br>Ds<br>darmstadtium<br>— | 111<br>Rg<br>roentgenium<br>— | 112<br>Cn<br>copernicium<br>— | 114<br>Fl<br>flerovium<br>— | 116<br>Lv<br>livermorium<br>— | —                           | —                            | —                         | —                         |  |  |

1  
H  
hydrogen  
1

**Key**  
atomic number  
atomic symbol  
name  
relative atomic mass

|                              |                            |                                 |                              |                             |                             |                             |                               |                            |                               |                              |                           |                               |                              |                              |
|------------------------------|----------------------------|---------------------------------|------------------------------|-----------------------------|-----------------------------|-----------------------------|-------------------------------|----------------------------|-------------------------------|------------------------------|---------------------------|-------------------------------|------------------------------|------------------------------|
| 57<br>La<br>lanthanum<br>139 | 58<br>Ce<br>cerium<br>140  | 59<br>Pr<br>praseodymium<br>141 | 60<br>Nd<br>neodymium<br>144 | 61<br>Pm<br>promethium<br>— | 62<br>Sm<br>samarium<br>150 | 63<br>Eu<br>europium<br>152 | 64<br>Gd<br>gadolinium<br>157 | 65<br>Tb<br>terbium<br>159 | 66<br>Dy<br>dysprosium<br>163 | 67<br>Ho<br>holmium<br>165   | 68<br>Er<br>erbium<br>167 | 69<br>Tm<br>thulium<br>169    | 70<br>Yb<br>ytterbium<br>173 | 71<br>Lu<br>lutetium<br>175  |
| 89<br>Ac<br>actinium<br>—    | 90<br>Th<br>thorium<br>232 | 91<br>Pa<br>protactinium<br>231 | 92<br>U<br>uranium<br>238    | 93<br>Np<br>neptunium<br>—  | 94<br>Pu<br>plutonium<br>—  | 95<br>Am<br>americium<br>—  | 96<br>Cm<br>curium<br>—       | 97<br>Bk<br>berkelium<br>— | 98<br>Cf<br>californium<br>—  | 99<br>Es<br>einsteinium<br>— | 100<br>Fm<br>fermium<br>— | 101<br>Md<br>mendelevium<br>— | 102<br>No<br>nobelium<br>—   | 103<br>Lr<br>lawrencium<br>— |

lanthanoids

actinoids

The volume of one mole of any gas is 24 dm<sup>3</sup> at room temperature and pressure (r.t.p.)